

# A DISTRIBUTED IN SITU SYSTEM FOR SNOW WATER EQUIVALENCE MEASUREMENT (WORK IN PROGRESS)

Christian Skalka<sup>1\*</sup>, Jeff Frolik<sup>2</sup>, and Beverley Wemple<sup>3</sup>

University of Vermont, Departments of <sup>1</sup>Computer Science, <sup>2</sup>Electrical Engineering, <sup>3</sup>Geography

**ABSTRACT:** We describe a ground-based system that provides quasi real-time measurement and collection of snow-water equivalent (SWE) data in remote settings. The system is significantly cheaper and easier to deploy than current methods and is more robust to terrain and snow bridging effects. The system also enjoys several possible remote data recovery solutions. Compared to current infrastructure using existing technology, our system features will combine to allow more sites to be installed for the same cost and effort, in a greater variety of terrain, enabling data collection at improved spatial resolutions. The system integrates a new computational architecture with new sensor technologies. Our computational architecture is based on *wireless sensor networks*, comprised of programmable, low-cost, low-powered nodes capable of sophisticated sensor control and remote data communication. Our sensor technology works by measuring *attenuation of electromagnetic radiation*, an approach that is immune to snow bridging and significantly reduces sensor footprints.

## 1. INTRODUCTION

The importance of snow water equivalence (SWE) estimation to science and society is well known. As suggested by Watson et al.<sup>1</sup> most snow studies are motivated by the need to estimate basin-wide runoff to provide operational forecasting for snow-affected industries or rivers subject to flooding, or to improve climate forecasting. These applications require knowledge about the spatial distribution of SWE over large spatial scales, often in basins characterized by complex terrain and heterogeneous land cover.

Prior research has demonstrated that SWE exhibits extreme variability in space. This variability is a result of influences of and interactions between meteorology (wind speed and direction, radiation), topography (elevation gradients, slope and aspect), and vegetation cover.<sup>2</sup> In temperate landscapes, forest vegetation exerts important controls on snow distribution through its role in intercepting snow, attenuating wind, and altering radiation at the snow surface.<sup>3 4 5 6 7</sup> Therefore, to obtain accurate SWE profiles of topographically complex areas, especially mountainous terrain, good temporal and spatial resolution is needed,

with techniques that are robust to the effects of vegetation cover.

While several approaches exist for measuring and quantitatively characterizing the spatial distribution of SWE, including manual surveys and airborne sensors, continuous, automated ground-based techniques allow for better spatial resolution, more frequent measurement, and are not affected by tree canopies. Emerging approaches exploit various technologies, including gamma ray detection and acoustics<sup>8 9 13</sup>, but these are largely still in the development phase and have not been deployed remotely as continuous, unmanned stations. The most prevalent ground-based, continuous method of SWE measurement makes use of *snow pillows*, which measure snow mass by measuring loads on liquid-filled bags (the pillow). In particular, the SNOTEL network run by the NRCS (Natural Resources Conservation Service) relies heavily on snow pillow technology. However, this method is susceptible to the phenomena of snow bridging (a gap forming between the snowpack and the ground). To mitigate (i.e., average out) the snow bridging effect, snow pillows are made large, approximately 50 to 100 square feet on average, and thus contain up to several hundred gallons of liquid, typically antifreeze. This means that snow pillows can only be installed in large, flat areas to accommodate their size, and near roads or well-established trails for transporting the apparatus. Large plate-style snow load sensors with multiple load nodes and

---

\*Corresponding author's address: Dept. of Computer Science, UVM, 33 Colchester Ave., Burlington, VT 05405, skalka@cs.uvm.edu.

associated analytic techniques to correct for snow bridging have been proposed to supplant snow pillows<sup>10</sup>, but this technology is not yet extensively used in practice.

The upshot of this is that in addition to inaccuracies due to snow bridging, predominant ground-based SWE measurement technologies do not provide effective resolution at the basin scale, due to their expense and difficulty of deployment. In the SNOTEL network this is exacerbated by the general reliance on traditional data logging platforms such as the CR1000, which are heavy, expensive, and power hungry. Indeed, most long-term continuously monitoring snow stations are located in clearings, representing a biased measurement of SWE. Thus, developing a system to cost effectively collect data to improve the spatial and temporal resolution of SWE monitoring would have important impacts on both the scientific study of snow and social infrastructures dependent on snow. Furthermore, a system that is compact and portable would have the advantage of being deployable in variety of settings including those presently not observable with remote sensing technologies (e.g., snow packs under forest canopies or on sloped terrain). And low cost would allow more data points to be measured, further improving spatial resolution, and would bring this technology to a broader user base.

In this paper we describe an ongoing research project to accomplish these goals. Our project can be characterized by three main goals, as follows; in the remaining text, we summarize research accomplishments and planned work relevant to these goals.

1. *To develop a cheap and easily deployable sensor platform that can be wirelessly networked, remotely accessed, and is robust to harsh winter environments.*
2. *To develop a new SWE measurement instrument suite and control algorithms suitable for integration with our platform, that is cheap, easily deployed, and robust to a variety of topographies.*
3. *To demonstrate and validate the proposed methods through an extensive field campaign.*

## **2. COMPUTATIONAL PLATFORM**

At the heart of our system is a computational and communications platform that will enable

instrumentation of environments with greater temporal and spatial resolutions than are presently possible in a relatively non-intrusive manner. Such a platform will not only serve our SWE effort but may be more broadly deployed for a wide range of environmental monitoring applications.

The enabling computational technology for our project is wireless sensor networks (WSNs) based on programmable motes, which are extremely lightweight, low-cost devices equipped with processor, RAM and Flash memory. Motes also have a radio transceiver capable of ~100 meter communication range, and can support a variety of data retrieval techniques. They easily integrate with a wide variety of sensors. The low cost of WSN motes (sub \$100 presently) and ease-of-use makes this technology within the means of virtually any user.

Our use of motes eliminates the wiring burdens and heavy enclosures required of traditional data logging mechanisms, and significantly reduces power requirements. Motes can be programmed with control algorithms for auxiliary circuitry managing activation of sources and sensors, to ensure that energy is expended in an efficient manner, and to dynamically adapt deployments to environmental conditions.

### 2.1. Research Accomplishments

We have developed a prototype system using compact snow pillows and load-cell scales as a simple proof-of-concept for our computational platform (Figure 1). This wireless sensing system was deployed to three locations at the base of Mount Mansfield (VT) during the 2007-2008 snow season.



**Figure 1: Prototype system deployment.**

Problems with power supplies prevented us from retrieving useful data over long periods, but important lessons about platform reliability and energy management were learned. Based on these experiences we have redesigned and ruggedized our power electronics and mechanical design (Figure 2); we are currently developing control software for and testing this new platform for field implementation during the 2008-2009 snow season. This platform is compact, inexpensive (less than \$300 as pictured), and easily deployable.

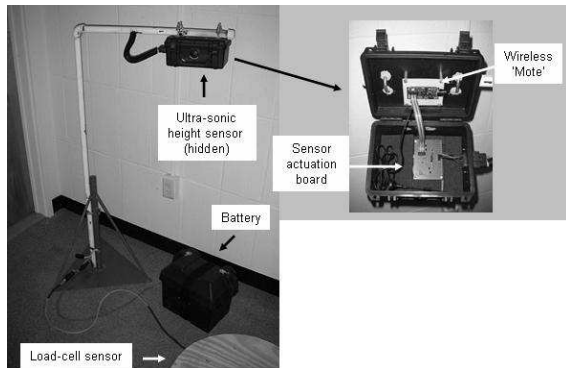
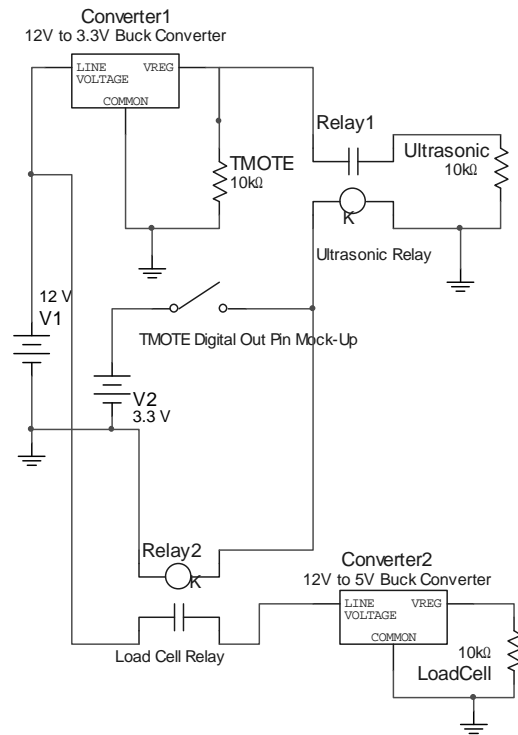

**Figure 2: Redesigned platform for 2008/2009 field study.**

**Circuitry and Power control.** To efficiently regulate the power source to the required voltage levels for each component of the system, dual DC-DC buck converters were used. The buck converters convert the 12VDC source down to 3.3VDC to power the mote and the Ultrasonic depth sensor, and 5 VDC to power the capacitive plate load cell.

The system currently is designed to take readings from the sensors hourly. This means that there is substantial time between readings when the sensors are not in use. By utilizing the output pins on the mote I/O, we can trigger a digital out pin to provide a signal which will switch a relay. This allows us to power down the 12-to-5V buck converter when the capacitive load cell sensor is not required to be in use. Another relay also allows the Ultrasonic sensor to be powered down by creating an open circuit. By powering down the 12 to 5V buck converter and turning off the Ultrasonic sensor, we are able to conserve otherwise wasted power which is important when dealing with a remote system and limited battery life.

Figure 3 shows the circuit used for the current scheme of the system. Previous models used NPN/PNP switches and Zener diodes to help regulate power consumption, but at a cost of continuous current draw. The current system helps alleviate these unnecessary battery draining flaws. The current system will also be fitted with an energy harvesting scheme (e.g. photovoltaics) to extend the current battery life even further.



**Figure 3: Power control circuit.**

**Data retrieval.** A mote-based platform supports a variety of data acquisition and retrieval techniques. The simplest is data logging, and subsequent retrieval over Ethernet connection with a laptop carried to the deployment site. However, off-the-shelf motes have only 1MB flash memory available for data logging, which is not sufficient for a full season of operation. Therefore, we have developed lightweight *data muling* options, where a site visitor carries a mule mote with a program that automatically downloads data to the mule when in radio transceiver range of the deployment. This exploits native features of WSNs, in particular they are designed to dynamically integrate new nodes into their network. Since the weight of a mote is negligible, this approach

allows more frequent site visits. Furthermore, we have determined that data produced in our project application by ~1-hour sampling intervals over a month easily fits into on-mote flash memory, so our data muling approach can be used in practice for SWE measurement without data loss.

A more sophisticated and interesting approach is remote data acquisition. Remote data acquisition is preferable in most settings, since retrieval is easier, faster (nearly real-time), and not dependent on physical accessibility of the deployment. Practical options here include radio modems and cell modems. Cell modem technology is particularly appealing since communication range is effectively unlimited for deployments in cell phone reception areas. We have recently integrated cell modems into our architecture. Using Multitech modems at the deployment site and at the data sink communicating via GPRS, we are able to establish a TCP/IP connection between the two. This standard protocol allows an easy interface to data storage and visualization applications at the sink. Furthermore, this TCP/IP connection will serve as an actuation channel, so we will be able to control the deployment remotely at the sink, for example to modify sampling rates for power management; see section 5.3 for more discussion of this point.

## 2.2. Work in Progress

Significantly, our use of WSN technology allows a single remote contact point at the deployment- (e.g. a single radio or cell-modem) to be used as a gateway for multiple sensing sites. Thus, while low cost of our individual stations will allow more to be deployed to obtain better spatial resolution, wireless networking technology will allow multiple sites in a given area to cooperate in routing data to a single gateway for communication to the sink. Such an area can be several acres, yielding an efficient technique for fine-grained monitoring at the basin scale. Power costs for such a scheme are realistic, as demonstrated by similar schemes used successfully in practice<sup>11</sup>. Data can also be mirrored within a WSN, meaning that our deployments can cooperate to log data redundantly. In terms of integrity of logged data, this would mitigate volatility of individual notes. We plan to develop software for data synchronization within the deployment WSN, and for interaction of a single gateway with all nodes within the WSN. The latter will allow

remote data collection and remote control from the data sink as discussed above.

## **3. SENSOR INSTRUMENTATION AND CONTROL**

In order to sidestep snow bridging issues and the consequent “bigger is better” constraint on load-measurement based approaches (e.g. snow pillows), we have focused on techniques that are based on attenuation of electromagnetic radiation. While these are power-consumptive, mote programmability will support algorithms that optimize power and measurement accuracy balances in various environmental conditions.

### 3.1 Research Accomplishments

*Radiation sensors.* Continuous ground-based measurement of SWE via detection of gamma ray attenuation in snow packs using small detectors has been studied previously by Osterhuber et al.<sup>12</sup>. Their techniques were successfully tested in very extreme conditions. We believe that detecting gamma ray attenuation is a promising approach, but there remain significant obstacles to overcome. In particular, to maintain low cost of deployment, it is necessary to find a balance between detector sensitivity and cost. Osterhuber et al. focused on detection of energies between 3MeV and 5MeV. A drawback of this approach is that detection of energies in the 3MeV to 5MeV range requires the use of scintillation detectors or Geiger-Muller tubes, which cost several thousand dollars on the current market. This is too expensive for our project vision.

However, the Domestic Nuclear Detection Office (DNDO) of the U.S. Department of Homeland Security has recently incentivized the development of low-cost gamma ray detectors sensitive in the 50KeV to 3MeV range as a component of the war on terrorism. This is documented and evidenced by the recent research funding efforts of the DNDO Transformational & Applied Research Directorate<sup>13</sup> and a recent Request for Information on Gamma Radiation Detection on FedBizOpps<sup>14</sup>. Our discussions with industry representatives suggest such detectors in the 500keV to 1MeV range will be available in the nearest future for \$150-\$300.

We have performed experiments with a Cadmium Zinc Telluride (CZT) gamma ray detector from eV Products<sup>15</sup>. Preliminary data (Figure 4), using all energies between 500 keV to 1.0 MeV, shows the measured attenuation of background radiation due to water. Also noted,

even in this preliminary data, is that attenuation results are non-linear and thus we can expect to develop new analytical relations for this sensor design.

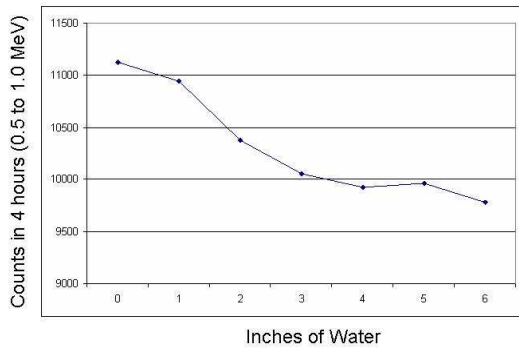

Figure 4: Gamma ray attenuation in water.

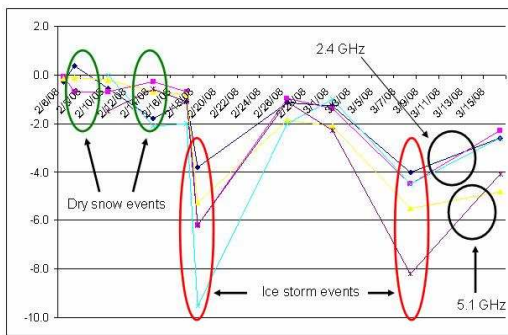

Figure 5: Susceptibility of microwave radiation to winter storm events having significant water content (R). Horizontal scale is in days, vertical scale is in relative attenuation in dB.

**Microwave sensors.** The attenuation characteristics of microwaves have been well studied<sup>16,17</sup> and in general are known to be high and dependent on water content. We are using this knowledge to develop a dual-band system (2.4 GHz and 5.1 GHz) in which signal strength is monitored at various heights. While attenuation rates are expected to be 20-100 dB/m in these bands depending on snow properties, we contend that measurements with large dynamic range, at various heights and at different frequencies, can be used to solve for SWE and potentially snow structure.

Proof of concept microwave attenuation data was collected during Winter 2008. The test setup consisted of a suite of patch antennas placed on the ground and two antennas mounted above the snow pack (one operating at

2.4 GHz and one operating at 5.1 GHz). From this data (Figure 5), we see that attenuation in both the 2.4 GHz and 5.1 GHz bands is susceptible to winter precipitation high in water content (e.g., from ice storms).

### 3.2 Work in Progress

Of the SWE measurement methods we are investigating, our preliminary data and related literature suggest that the CZT device is the most accurate in terms of SWE measurements and least susceptible to inclusions in the snow pack (e.g., ice lenses, air/water pockets). However, as noted, due its power requirements it is not feasible for this device to be utilized continually so we will be developing a multi-parameter, multi-tiered, adaptive sampling algorithm to optimize a balance of measurement accuracy and energy usage..



Figure 6: Multimodal sensor control algorithm.

While the concept of adaptive sampling in sensor networks is not new, approaches to date have tended to focus on the sampling of independent parameters. Our approach differs in that the sampling of a particular sensor is *conditional* on previous and current values found on *other* sensors. In our system, the sensors having the least energy draw (i.e., ultrasound) are the least accurate in determining SWE (i.e., only snow pack depth is measured). Conversely, our ‘best’ SWE (i.e., CZT) also requires a relatively large amount of energy. However, the depth sensor would be capable of capturing a new snow event. Also, temperature sensors within the snow pack may be utilized to detect melt conditions. That is, these simple and low-energy modalities can run at high sampling intervals and be used to trigger subsequent sensors that would provide new information (Figure 6). For example, should a snow fall be detected via depth change (cost of ~5 mA) our algorithms will then trigger a microwave measurement (cost of ~50 mA). Should the snow fall be very dry (i.e., little water content) our results (Figure 5) indicate there will be very

little variation in signal strength. However, snow events high in water content will show significant changes in microwave signal strength. Such measurements will then be used to trigger a CZT measurement (cost of ~500 mA).

This multi-tiered, event-driven approach can be coded as simple rules that can be readily implemented upon resource-constrained motes running TinyOS. However, we presently do not have a clear idea as to the thresholds that trigger the next most information rich (and energy consuming) sensor. Thus there is a need to ensure these algorithms adapt *in situ* with the goal of providing timely SWE data while minimizing overall energy use. In this respect, remote control of instrumentation via cell modem as discussed in Section 2 will be useful to control thresholds based on off-site data analysis.

#### 4. FIELD VALIDATION

The role of conifer forests in influencing snow distribution and melt has been widely recognized from studies in the western U.S.<sup>3,4,5,6,7</sup>, but eastern deciduous forests have received comparatively little attention<sup>18</sup>. Recent assessments of land use change suggest that forests of the eastern U.S. are under-going rapid conversion as development extends into the largely forested areas of northern New England.<sup>19</sup> Our research into these issues provides a field validation opportunity for the SWE measurement system described herein.

##### 4.1 Research Accomplishments

Our recent research suggests that forest clearing produces detectable differences in snow accumulation and melt, relative to forested settings.<sup>20</sup> Using paired forested and cleared sites along an elevational gradient on the eastern slope of Mt. Mansfield, we measured SWE at peak accumulation and after snowmelt commenced during the winter of 2007. Our data indicate that SWE differs significantly between forested and cleared sites at the highest elevations, where conifers dominate (Figure 7). Our on-going research plans aim at corroborating these findings through a more rigorously based field campaign, making use of our sensing technology for distributed remote measurements, as described below.

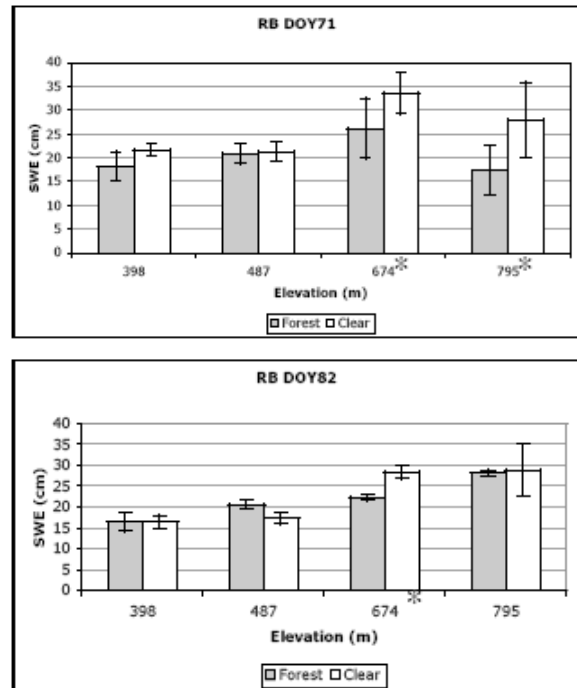

**Figure 7: SWE differences at forested and cleared sites, Ranch Brook (RB) watershed, Vermont.** Mean and standard deviations are based on 3-5 samples per site collected on March 12 (DOY 71) at peak accumulation and March 23 (DOY 82), after snowmelt commenced in 2007. Asterisks represent significant differences in mean SWE at  $\alpha = 0.05$ .

##### 4.2 Work in Progress

In order to further field test our sensor technology and examine the role of forest vegetation on snow accumulation, we will deploy our prototypes as data-collection nodes at the Hubbard Brook Experimental Forest (HBEF), an NSF-supported long-term ecological research (LTER) site located in northern New Hampshire, where an on-going program of snow monitoring exists. Important advantages will accrue to us in field testing at this location: (1) we will co-locate a sensor near a long-term climate monitoring station<sup>21</sup>, where continuous measurements of snow water equivalent have been recorded at an hourly time step since 2002, providing a continuous time-series ground truth for our sensor; (2) we will select additional deployment sites for sensors that correspond to locations of weekly snow courses sampled by HBEF field staff, providing a coarser time-resolution ground

truth for additional sensors deployed; and (3) we will select sites for deployment that allow us to relate snowpack dynamics to characteristics of the forest canopy (i.e. basal area, canopy or branch density) relative to that of nearby canopy clearings, by locating sensors in clearings and adjacent plots where vegetation metrics have been measured. The field sites are remote, situated in complex terrain, require considerable manual labor to access and maintain, and are hence ideal settings for a robust field test of our technology. We will make the dataset from this installation publicly available through the online data archives managed by the Hubbard Brook Experimental Forest as an NSF-supported LTER site.

#### ACKNOWLEDGEMENTS

Thanks to Matt Casari for providing circuitry diagrams and wiring descriptions. Thanks to Charles Robinson, Matt Seekins, Tiffany Larsen, and Chris Henwood for their help with the prototype deployment.

#### REFERENCES

- <sup>1</sup> Watson, F., T. Anderson, W., S. Alexander, and R. Garrott, "Optimal sampling schemes for estimating mean snow water equivalents in stratified heterogeneous landscapes," *Journal of Hydrology*, 328, 432-452, 2006.
- <sup>2</sup> McKay, G., and D. Gray, "The distribution of snowcover." In *Handbook of Snow: Principles, Processes, Management and Use*, D. M. Gray and D. H. Male (eds). Pergamon Press: Toronto, 153-190, 1981.
- <sup>3</sup> Pomeroy, J., D. Gray, N. Hedstrom, and J. Janowicz, "Prediction of seasonal snow accumulation in cold climate forests," *Hydrological Processes*, 16: 3543-3558, 2002.
- <sup>4</sup> Koivusalo, H. and T. Kokkonen, "Snow processes in a forest clearing and in a coniferous forest," *Journal of Hydrology*, 262, 145-164, 2002.
- <sup>5</sup> Woods, S., R. Ahl, J. Sappington, and W. McCaughey, "Snow accumulation in thinned lodgepole pine stands, Montana, USA," *Forest Ecology and Management*. DOI:10.1015/j.foreco.2006.08.013, 2006.
- <sup>6</sup> Lopez-Moreno, J. and J. Latron, "Influence of canopy density on snow distribution in a temperate mountain range," *Hydrological Processes* DOI: 10.1002/hyp6572. 2007

- <sup>7</sup> Jost, G., M. Weiler, D. Gluns, and Y. Alila, "The influence of forest and topography on snow accumulation and melt at the watershed-scale," *Journal of Hydrology*, 347: 101-115, 2007.
- <sup>8</sup> Gubler, H., "An inexpensive snow depth gauge based on ultrasonic wave reflection from the snow surface," *Journal of Glaciology*, 27(95): 157-163.
- <sup>9</sup> Goodison, B., B. Wilson, K. Wu and J. Metcalfe, "An inexpensive remote snow-depth gauge: an assessment," *Proceedings of the Western Snow Conference*, 52:188-191, 1984.
- <sup>10</sup> Johnson, J. and Marks, D., "The detection and correction of snow water equivalent pressure sensor errors", *Hydrological Processes* 18(18): 3513-3525, 2004.
- <sup>11</sup> Werner-Allen, G. et al., "Deploying a wireless sensor network on an active volcano," *IEEE Internet Computing*, March/April 2006, pp. 18-25.
- <sup>12</sup> Osterhuber, R., and F Gehrke, and K. Condreva, "Snowpack snow water equivalent measurement using the attenuation of cosmic gamma radiation," *Western Snow Conference*, April 1998.
- <sup>13</sup> DHS DNDO Transformational & Applied Research Directorate, Ongoing Research Projects: [http://www.dhs.gov/xlibrary/assets/DNDO\\_List.pdf](http://www.dhs.gov/xlibrary/assets/DNDO_List.pdf). (accessed: 07/01/08)
- <sup>14</sup> DHS DNDO Request for Information on Mobile COTS and Gamma Radiation Detection Equipment: <http://www.fbo.gov/spg/DHS/OCPO/DHSOCP/O/Reference%2DNumber%2DRFI%2DRadNucCOTS/Synopsis.html> (accessed: 07/01/08).
- <sup>15</sup> eV products website: <http://www.evproducts.com/>
- <sup>16</sup> Ulaby, F., R. Moore and A. Fung, *Microwave Remote Sensing: Passive and Active, Vol. III*, Artech House, Inc., 1986.
- <sup>17</sup> Abe, T., Y. Yamaguchi, M. Sengoku, "Experimental study of microwave transmission in snowpack," *IEEE Trans. Geosc. and Rem. Sens.*, Vol. 28, No. 5, September 1990.
- <sup>18</sup> Murray, C. D. and J. M. Buttle, "Impacts of clearcut harvesting on snow accumulation and melt in northern hardwood forest," *Journal of Hydrology*, 271: 197-212, 2003.
- <sup>19</sup> Stein, S. M., R. E. McRoberts, R. J. Alig, M. D. Nelson, D. M. Theobald, M. Eley, M. Dechter,

---

and M. Carr, "Forests on the Edge: Housing Development on America's Private Forests," *USDA Forest Service, General Technical Report GTR-636*, Pacific Northwest Research Station, 2005.

<sup>20</sup> Larsen, T., B. Wemple, and W. Keeton, "Forest Cover and Topographic Influences on Snow Distribution in a Mixed Hardwood-Conifer Forest of the Northeastern U.S." *EOS Transactions* (Fall Meeting Supplement), American Geophysical Union, C21B-0447, 2007.

<sup>21</sup> Natural Resources Conservation Service (NRCS) SCAN site # 2069, see: [http://www.wcc.nrcs.usda.gov/scan/site.pl?site\\_num=2069&state=nh](http://www.wcc.nrcs.usda.gov/scan/site.pl?site_num=2069&state=nh).